

Type 4015 DC-G



Bestell-Nr. 1003 2627

Anwendungen	Gravieren
Spanndurchmesser	35 mm
Motorart	Drehstromsynchronmotor
Drehzahlbereich	5.000 - 80.000 min ⁻¹
Spannung	26 V
Strom	max. 8 A
Drehmoment	max. 4 Ncm
Frequenz	83 - 1.333 Hz
Leistung	max. 300 W
Gewicht	0,5 kg
Lagerung	3 x Hybrid, lebensdauergeschmiert
Schutzart	IP 54
Motorschutz	-
Gebrauchslage	
Belastungsrichtung	axial + radial
Rundlauf (Kegel)	≤ 1,5 µm
Spannzangenbereich	Ø 0,5 - 4,0 mm (inkl. 1/8")
Werkzeugwechsel	1 Schlüssel (SW 8) + 1 Steckschlüssel
Kühlsystem	durch Einspannvorrichtung (Fremd)
Geschützt gegen Schmutz und Kühlschmiermittel	Sperrluft 0,5 - 0,8 bar (Schlauch Ø innen/außen 2,5/4 mm)
Gehäusematerial	Edelstahl
Verbindungskabel	5,0 m
Umrichterempfehlung	e@syDrive® 4310 (IP00), 4320 (IP00), 4424*, 4425, TV 4504
Besonderheiten	<ul style="list-style-type: none"> • Integrierte Höhenregulierung • Einstellbare Tiefenregulierung • Adaptierbar an gängige Anlagen

Part No. 1003 2627

Applications	Engraving
Clamping diameter	35 mm
Motor system	Brushless DC motor (BLDC)
Speed range	5,000 - 80,000 rpm
Voltage	26 V
Current	max. 8 A
Torque	max. 4 Ncm
Frequency	83 - 1,333 Hz
Output power	max. 300 W
Weight	0.5 kg
Bearing system	3 x Hybrid, lifetime lubrication
Protection category	IP 54
Motor protection	-
Working position	
Load direction	axial + radial
Run-out (taper)	≤ 1.5 µm
Chuck clamping range	Ø 0.5 - 4.0 mm (incl. 1/8")
Tool change	1 wrench (8 mm) + 1 socket wrench
Cooling system	via clamping bracket (external)
Protected against dirt and cooling lubricant	Sealing air 0.5 - 0.8 bar (hose Ø inner/outer 2.5/4 mm)
Housing material	Stainless steel
Connecting cable	5.0 m
Inverter recommendation	e@syDrive® 4310 (IP00), 4320 (IP00), 4424*, 4425, TV 4504
Highlights	<ul style="list-style-type: none"> • Integrated floating system • Adjustable cutting depth control • Adaptable to common equipment

*reduzierte Leistung

Änderungen vorbehalten

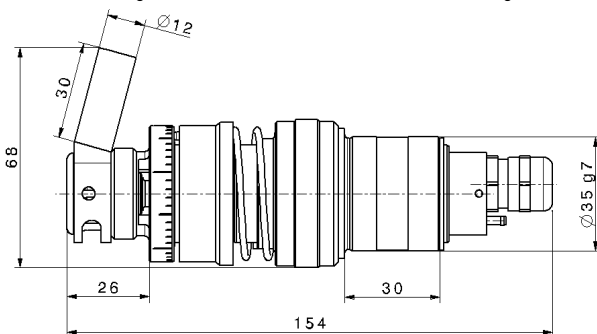

*reduced output power

Subject to change without notice

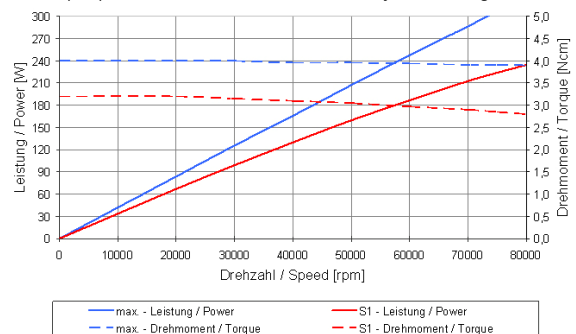

INDUSTRIAL DRIVES

SycoTec GmbH & Co. KG
 Wangener Strasse 78
 88299 Leutkirch
 Germany

Phone +49 7561 86-0
 Fax +49 7561 86-371
 info@sycotec.eu
 www.sycotec.eu

