

Type 4015 DC-R-HSK63



Bestell-Nr. 2001 4008	
Anwendungen	Bohren, Fräsen, Schleifen, Gravieren
Maschinenaufnahme	HSK 63
Motorart	Drehstromsynchronmotor
Drehzahlbereich	5.000 - 80.000 / 100.000* min ⁻¹
Spannung	32 V
Strom	max. 8 A
Drehmoment	max. 4 Ncm
Frequenz	83 - 1.333 / 1.666* Hz
Leistung	max. 300 W
Gewicht	1,65 kg (inkl. HSK63)
Lagerung	3 x Hybrid, lebensdauergeschmiert
Schutzart	IP 54
Motorschutz	-
Gebrauchslage	
Belastungsrichtung	axial + radial
Rundlauf (Kegel)	≤ 1,5 µm
Spannzangenbereich	Ø 0,5 - 4,0 mm (inkl. 1/8")
Werkzeugwechsel	2 Gabelschlüssel (SW 8 + 11)
Kühlsystem	Kühlung durch Einspannvorrichtung
Geschützt gegen Schmutz und Kühlschmiermittel	Sperrluft 0,5 - 0,8 bar (Schlauch Ø innen/außen 2,5/4 mm)
Gehäusematerial	Edelstahl
Verbindungskabel	2,0 m (Steckerbuchse)
Umrichterempfehlung	e@syDrive® 4310 (IP00), 4320 (IP00), 4424**, 4425, TV 4504
Besonderheiten	optional mit allen Standardaufnahmen lieferbar (z.B. Capto / SK)

Part No. 2001 4008	
Applications	Drilling, Milling, Grinding, Engraving
Machine adapter	HSK 63
Motor system	Brushless DC motor (BLDC)
Speed range	5,000 - 80,000 / 100,000* rpm
Voltage	32 V
Current	max. 8 A
Torque	max. 4 Ncm
Frequency	83 - 1,333 / 1,666* Hz
Output power	max. 300 W
Weight	1.65 kg (incl. HSK63)
Bearing system	3 x Hybrid, lifetime lubrication
Protection category	IP 54
Motor protection	-
Working position	
Load direction	axial + radial
Run-out (taper)	≤ 1.5 µm
Chuck clamping range	Ø 0.5 - 4.0 mm (incl. 1/8")
Tool change	2 open-end wrenches (8 + 11 mm)
Cooling system	Cooling via clamping bracket
Protected against dirt and cooling lubricant	Sealing air 0.5 - 0.8 bar (hose Ø inner/outer 2.5/4 mm)
Housing material	Stainless steel
Connecting cable	2.0 m (female plug)
Inverter recommendation	e@syDrive® 4310 (IP00), 4320 (IP00), 4424**, 4425, TV 4504
Highlights	optionally available with all standard machine adapters (e.g. Capto / SK)

*kurzzeitig
**reduzierte Leistung

Änderungen vorbehalten

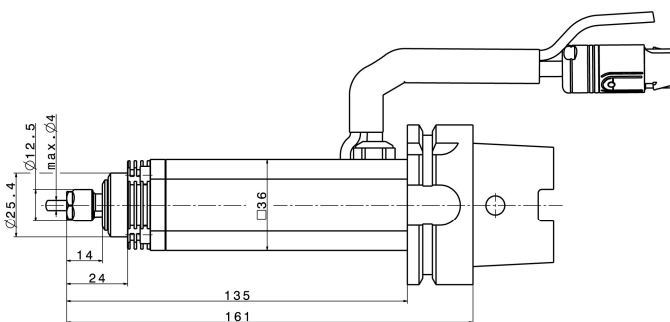

*short term
**reduced output power

Subject to change without notice

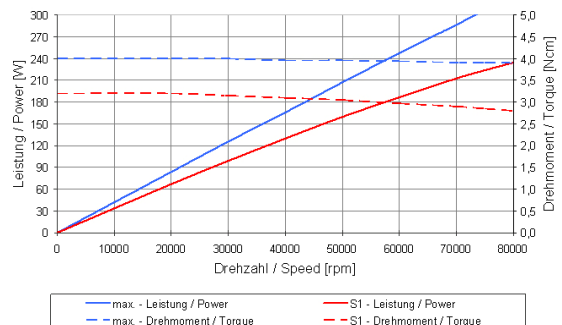

INDUSTRIAL DRIVES

SycoTec GmbH & Co. KG
Wangener Strasse 78
88299 Leutkirch
Germany

Phone +49 7561 86-0
Fax +49 7561 86-371
info@sycotec.eu
www.sycotec.eu

