

4033 AC



Bestell-Nr. | Part No. **2000 7550**

Anwendungen	Bohren, Fräsen, Schleifen, Gravieren
Drehzahlbereich	6.000 – 100.000 min ⁻¹
Leistung	max. 500 W
Spanndurchmesser	33 mm
Motorart	3 Phasen-Asynchronmotor
Frequenz	100 – 1.666 Hz
Spannung	max. 60 V
Strom	max. 8 A
Drehmoment	max. 8,4 Ncm
Motorschutz	KTY
Gewicht	1,0 kg
Lagerung	3 x Hybrid, lebensdauergeschmiert
Rundlauf (Kegel)	≤ 1 µm
Spannzangenbereich	max. Ø 4,0 mm
Spannzangentyp	C3
Werkzeugwechsel	Pneum. 5 – 6 bar (Schlauch Ø 4 mm)
Kühlsystem	Kühlung durch Einspannvorrichtung
Schutzart	IP 55/57 (mit Sperrluft + optionalem Zubehör: Dichtkappe 2001 2618)
Geschützt gegen Schmutz und Kühlschmiermittel	Sperrluft 27 l/min (Schlauch außen Ø 4 mm)
Gehäusematerial	Edelstahl
Kabel / Steckertyp	915
Umrichterempfehlung	e@syDrive® 4310(IP00)*, 4320(IP00)*, TV4503*, TV4504*, TV4506, 4624*, 4625, 4626
Besonderheiten	Kegelreinigung bei 6 bar

Applications	Drilling, milling, grinding, engraving
Speed range	6,000 – 100,000 rpm
Output power	max. 500 W
Clamping diameter	33 mm
Motor system	3 Phase asynchronous motor
Frequency	100 – 1,666 Hz
Voltage	max. 60 V
Current	max. 8 A
Torque	max. 8.4 Ncm
Motor protection	KTY
Weight	1.0 kg
Bearing system	3 x Hybrid, lifetime lubrication
Run-out (taper)	≤ 1 µm
Chuck clamping range	max. Ø 4.0 mm
Chuck type	C3
Tool change	Pneumatic 5 – 6 bar (hose Ø 4 mm)
Cooling system	Cooling via clamping bracket
Protection category	IP 55/57 (with sealing air + optional accessory: sealing cap 2001 2618)
Protected against dirt and cooling lubricant	Sealing air 27 l/min@STP (hose outer Ø 4 mm)
Housing material	Stainless steel
Cable / plug type	915
Inverter recommendation	e@syDrive® 4310(IP00)*, 4320(IP00)*, TV4503*, TV4504*, TV4506, 4624*, 4625, 4626
Highlights	Taper cleaning at 6 bar

*reduzierte Leistung

Änderungen vorbehalten

*reduced output power

Subject to change without notice

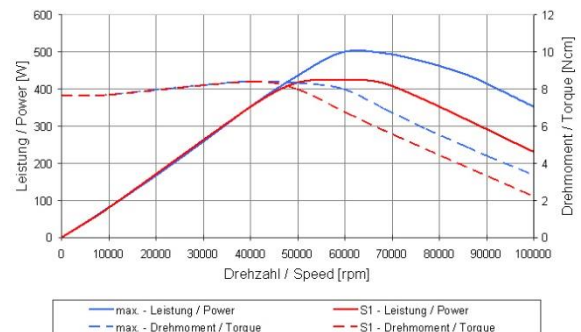
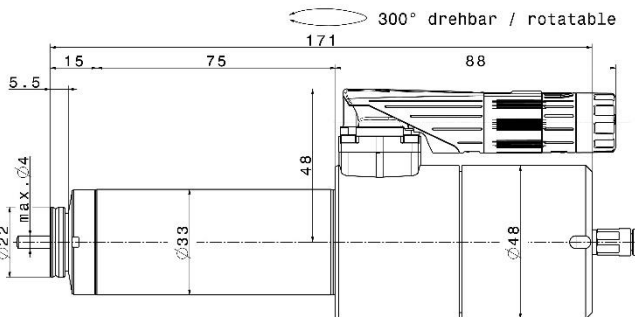

2018-08