

# 4033 AC-ESD



(Abb. ähnlich | fig. similar)

Bestell-Nr. | Part No. **2001 3535**

<b>Anwendungen</b>	Leiterplatten fräsen
<b>Drehzahlbereich</b>	6.000 – 100.000 min <sup>-1</sup>
<b>Leistung</b>	max. 500 W
<b>Spanndurchmesser</b>	33 mm
<b>Motorart</b>	3 Phasen-Asynchronmotor
<b>Frequenz</b>	100 – 1.666 Hz
<b>Spannung</b>	max. 60 V
<b>Strom</b>	max. 8 A
<b>Drehmoment</b>	max. 8,4 Ncm
<b>Motorschutz</b>	KTY
<b>Gewicht</b>	1,0 kg
<b>Lagerung</b>	3 x Hybrid, lebensdauergeschmiert
<b>Rundlauf (Kegel)</b>	≤ 1 µm
<b>Spannzangenbereich</b>	max. Ø 4,0 mm
<b>Spannzangentyp</b>	C3
<b>Werkzeugwechsel</b>	Pneum. 5 – 6 bar (Schlauch Ø 4 mm)
<b>Kühlsystem</b>	Kühlung durch Einspannvorrichtung
<b>Schutzart</b>	IP 55/57 (mit Sperrluft + optionalem Zubehör: Dichtkappe 2001 2618)
<b>Geschützt gegen Schmutz und Kühlschmiermittel</b>	Sperrluft 27 l/min (Schlauch außen Ø 4 mm)
<b>Gehäusematerial</b>	Edelstahl
<b>Kabel / Steckertyp</b>	915
<b>Umrichterempfehlung</b>	e@syDrive® 4310(IP00)*, 4320(IP00)*, TV4503*, TV4504*, TV4506, 4624*, 4625, 4626
<b>Besonderheiten</b>	Ableitung elektrostatischer Aufladung

<b>Applications</b>	PCB routing
<b>Speed range</b>	6,000 – 100,000 rpm
<b>Output power</b>	max. 500 W
<b>Clamping diameter</b>	33 mm
<b>Motor system</b>	3 Phase asynchronous motor
<b>Frequency</b>	100 – 1,666 Hz
<b>Voltage</b>	max. 60 V
<b>Current</b>	max. 8 A
<b>Torque</b>	max. 8.4 Ncm
<b>Motor protection</b>	KTY
<b>Weight</b>	1.0 kg
<b>Bearing system</b>	3 x Hybrid, lifetime lubrication
<b>Run-out (taper)</b>	≤ 1 µm
<b>Chuck clamping range</b>	max. Ø 4.0 mm
<b>Chuck type</b>	C3
<b>Tool change</b>	Pneumatic 5 – 6 bar (hose Ø 4 mm)
<b>Cooling system</b>	Cooling via clamping bracket
<b>Protection category</b>	IP 55/57 (with sealing air + optional accessory: sealing cap 2001 2618)
<b>Protected against dirt and cooling lubricant</b>	Sealing air 27 l/min@STP (hose outer Ø 4 mm)
<b>Housing material</b>	Stainless steel
<b>Cable / plug type</b>	915
<b>Inverter recommendation</b>	e@syDrive® 4310(IP00)*, 4320(IP00)*, TV4503*, TV4504*, TV4506, 4624*, 4625, 4626
<b>Highlights</b>	Electrostatic discharge

\*reduzierte Leistung

Änderungen vorbehalten

\*reduced output power

Subject to change without notice

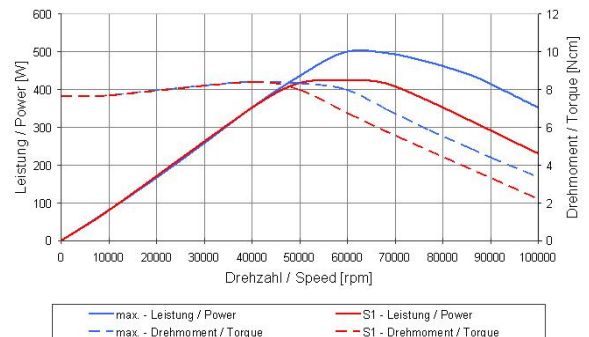
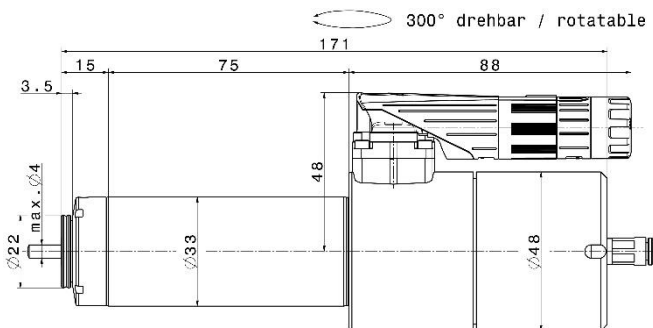

2018-08